

EXPLOSION-PROOF RECHARGEABLE HAND LAMP SLE 16 LED SET

Zones 1, 2, 21, 22

Full catalogue available on our website: www.inpratex.com

ATEX FLASHLIGHTS

ZONES 1, 2 (gas) & 21, 22 (dust)



The microprocessor controlled, rechargeable hand lamp, model EX SLE 16 LED, made of impact-resistant, high-quality plastic was certified according to the directive 2014/34/EU and relevant EMC provisions and may be used in vehicles.

The EX SLE 16 LED can be operated in a permanent, blinking and pilot lamp function and used as a warning light.



Flexible lamp head.

4-stage charge level display.

Emergency light function, turns on in the event of a power failure.

Maintenance-free led gel rechargeable battery.

12V-24V charger included.



EU-Type Examination Certificate

ITEM REFERENCES

Model:	Item No.:
EX SLE 16 LED SET	1E0303

TECHNICAL SPECIFICATIONS

Marking:	II 2G Ex ib IIC T4 Gb II 2D Ex ib IIC T135°C Db
Certificate:	EU-Type Examination Certificate
Housing:	Plastic, shock-resistant
Ingress protection:	IP64
Lamp:	Power LED (approx. 180 lm)
Run time:	Approx. 5h
Beam distance:	Approx. 170 m
Pilot lamp:	LED 5 mm
Operating time pilot lamp:	Approx. 75h
Rechargeable battery:	Lead-gel rechargeable battery Maintenance-free
Charging voltage:	230V AC 50/60Hz, 12/24V DC
Weight:	1100 g
Dimensions:	104x245x120 mm
Operating temperature:	-20°C to +40°C

Dimensions in mm

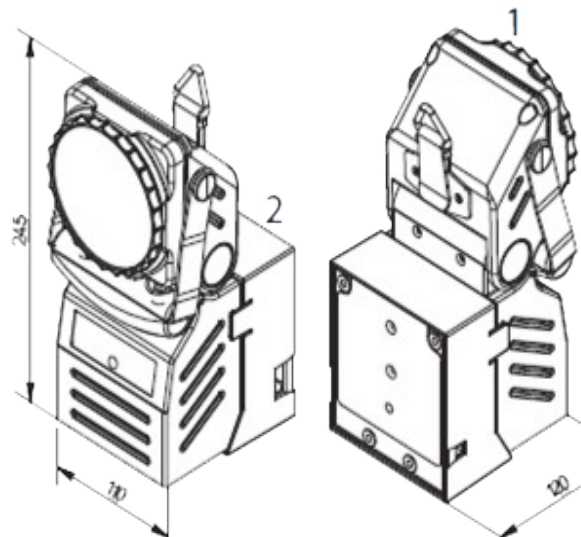

Dimensions AccuLux EX SLE 15 LED
Dimensions AccuLux EX SLE 16 LED